



*Electromechanical repeat cycle timer housed in standard CYCL-FLEX® case... Knob setpoint, cycle progress pointer, pilot light, and patented plug-in housing*



6

ELECTRIC  
TIMERS

The HP7 series timer is a high quality, synchronous motor driven repeat cycle timer housed in the standard CYCL-FLEX® plug-in housing.

- 7 standard time ranges from 60 seconds to 10 hours
- Knob/Pointer adjustable time ranges - another pointer shows cycle progress
- Highly visible, calibrated dials (7.85 inch circumference)
- Output switch transfer at end of timing cycle
- Pilot light indicates when timer motor is energized
- Standard timers supplied with "power on" clutch operation
- Optional reverse action clutch will not reset on power failure
- 15 terminal ABS (UL rated 94V-0) molded housing has high impact resistance and will not support combustion

**OPERATION**

The HP7 Series timer is available in seven time ranges from 60 seconds to 10 hours. Time settings are made by a knob and pointer against a calibrated scale on the front of the unit. A second pointer indicates cycle progress. Output switch transfer at the end of each timing cycle provides an output pulse for the duration of 1% (nominal) of the maximum dial range. At the end of a 1 second reset period, the unit starts another timing cycle. The HP7 timer will not reset on power interruption or failure.

**SPECIFICATIONS**

Time Ranges:

Sym.	Dial	Minimum Setting	Output Pulse Duration
1	60 Sec.	2 Sec.	.3 to .9 Sec.
3	5 Min.	9 Sec.	1.5 to 4.5 Sec.
4	10 Min.	20 Sec.	3 to 9 Sec.
5	30 Min.	1 Min.	9 to 27 Sec.
6	60 Min.	2 Min.	.18 to .54 Sec.
7	150 Min.	4.5 Min.	45 to 135 Sec.
9	10 Hrs.	20 Min.	3 to 9 Min.

**Repeatability:** (constant voltage and temperature): ±2%

**Setability:** Within ±2% of maximum range

**Reset Time:** 1 second ±20%

**Cycle Progress:** Indicated by red pointer

**Voltage/Frequency:** 120V (+10, -15%), 60 Hz

**Burden:** Motor: 2.5 VA, 120 VAC  
Clutch: 10.5 VA, 120 VAC

**Output Pulse:** 1% (nominal) of dial range

**Output Rating:** 10 amps, 120 VAC 50/60Hz

**Power Interruption:** Unit will not reset on power interruption or failure

**Temperature Range:** 0° to 140°F (-18° to +60°C)

**Vibration:** Unaffected by 2.5G sinusoidal vibration magnitudes in both directions of three perpendicular mounting axes imposed from 20 to 900 Hz

**Approximate Weight:** 2 lb. 14 oz.

**Agency Approvals:** UL Recognition E61735  
CSA Certification LR26861  
RoHS

**REFERENCE EAGLE SIGNAL BULLETIN NUMBER 325**

## SCHMATIC DIAGRAM

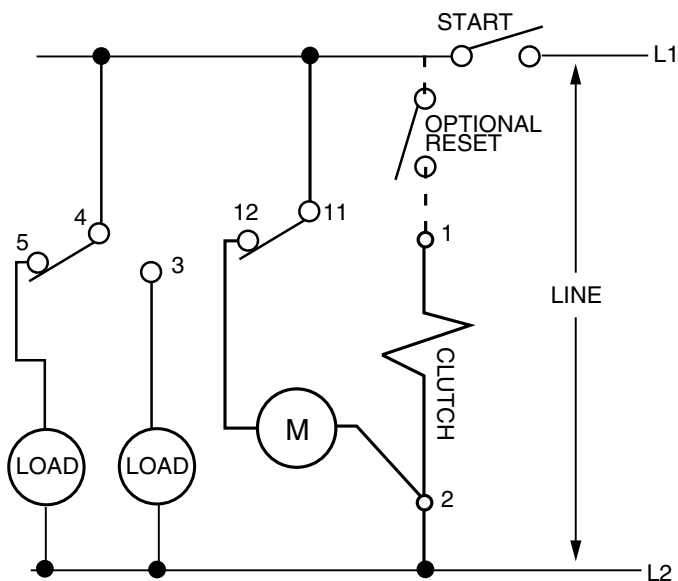

## MOUNTING

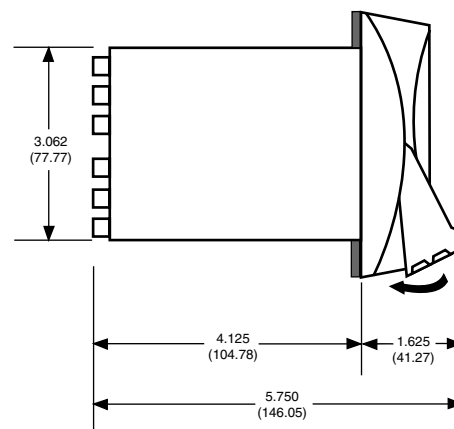
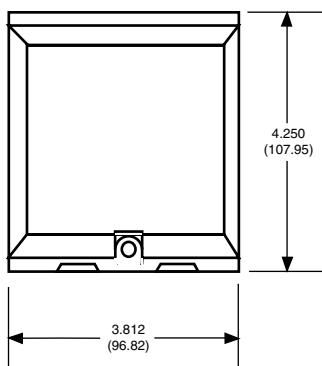
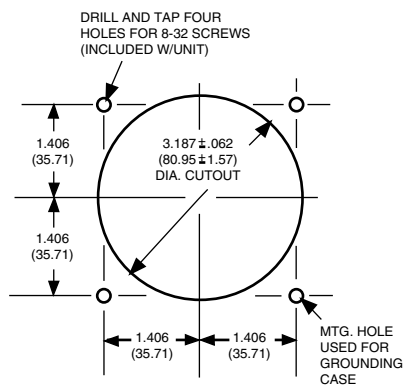

## ORDERING INFORMATION

### TIME RANGE

Sym.	Description
1	0-60 Sec.
3	0-5 Min.
4	0-10 Min.
5	0-30 Min.
6	0-60 Min.
7	0-150 Min.
9	0-10 Hr.

**HP7**

**5**

**A6**

**07**

### VOLTAGE & FREQUENCY

Sym.	Description
A6	120V, 60 Hz

### FEATURES

Sym.	Description
(Blank)	Standard
07	Dial Lock

\*Laboratory Testing: UL Recognition E61735  
CSA Certification LR45132-1